

Gerst-traffic

LED-Lamp for 200 mm - Traffic-Signals
Datasheet GE-5035.0309

Power consumption

	Red	Yellow	Green
DC 12 V	265 mA	265 mA	620 mA
DC 24 V	160 mA	160 mA	275 mA
AC 230 V	60 mA	60 mA	70 mA

Optical Values (All colours)

Brightness	Class B2/2 by EN 12386.
Splendor-angle	Type W
Light-density	1:10
Phantom-signal	Class 4

Environmental

Working temperature range	-40°C up to +85°C Class B
EMC-Requirements	in accordance with EN 50278

Mechanical Data

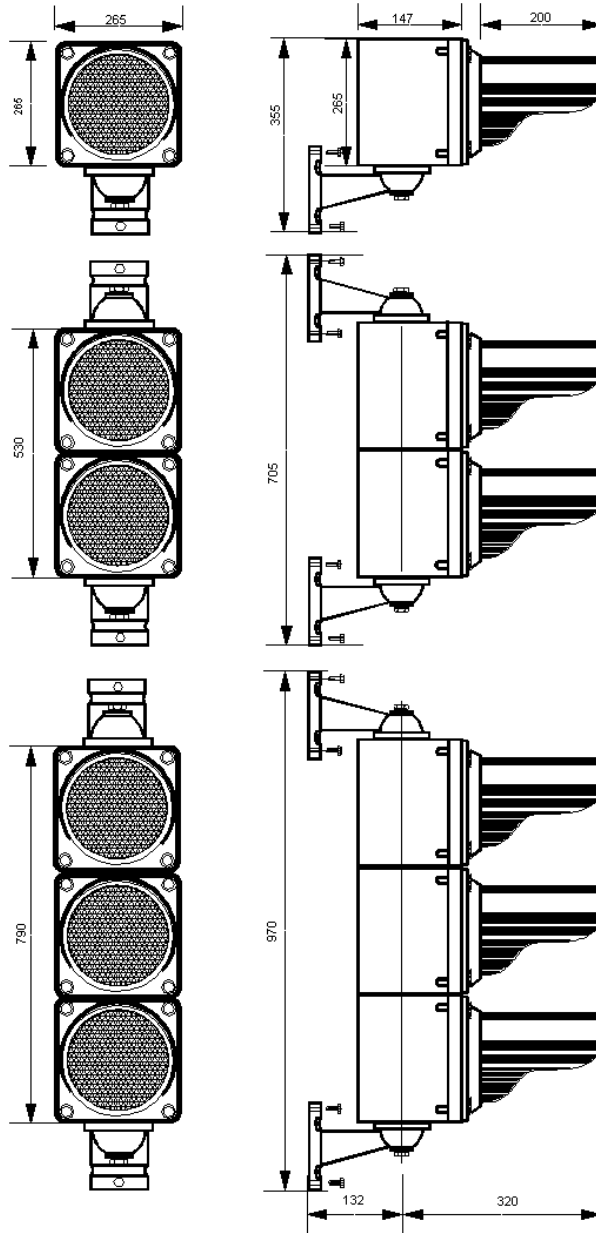

Connecting Diagram

